



www.roadstersolutions.com

1-877-862-0585

54 31 013 Replacing rear window in convertible top (Z3 roadster, M roadster)

Caution!

Vehicle must be brought to room temperature of approx. 20° C.

The rear window and the convertible top must not come into contact with solvents, greases etc.

The work should be carried out with a second person.



Lower all side windows.

Unlock convertible top and lift somewhat.

Note:

Protect rear window frame and side panels from damage.

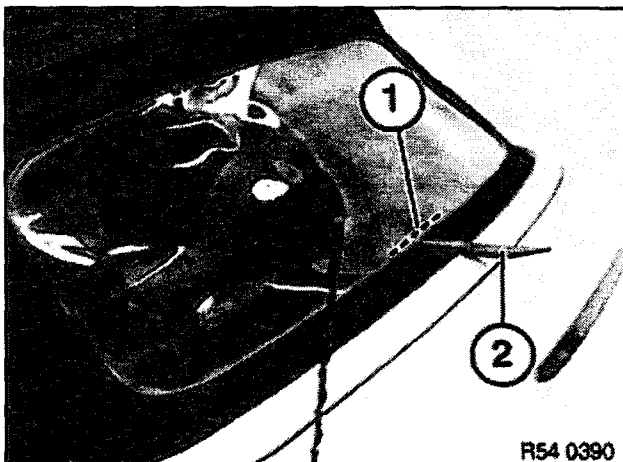

Raise profile piping below center with folding leg and pull fabric approx. 100 mm out of profile piping.

1. Rear window

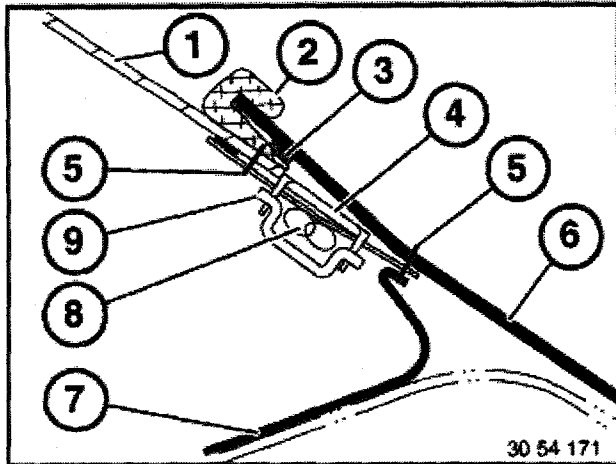

2. PVC profile piping
3. Sealing tape
4. Locking clip
5. Seam
6. Cover fabric
7. Top cloth (rear window tail strip)
8. Zip fastener
9. Counter-support plate

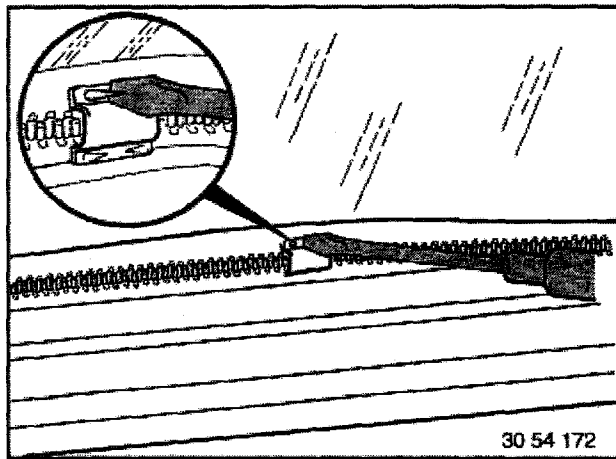

Bend over four claws on retaining clips on inside edge of rear window (below center) using screwdriver.

Caution!

Do not damage zip fastener.

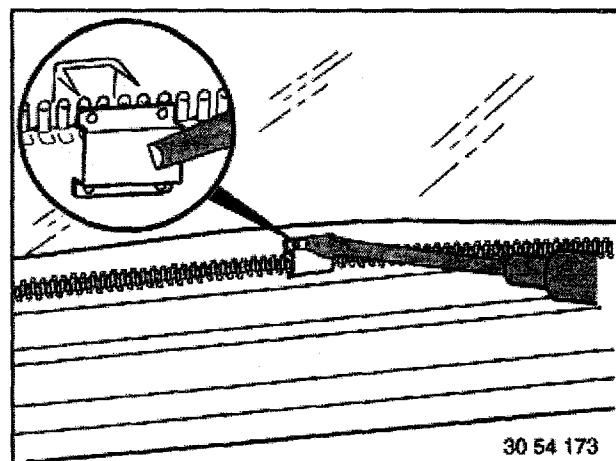

Remove counter-support plate from inside of rear window.

Extract retaining clip from outside.

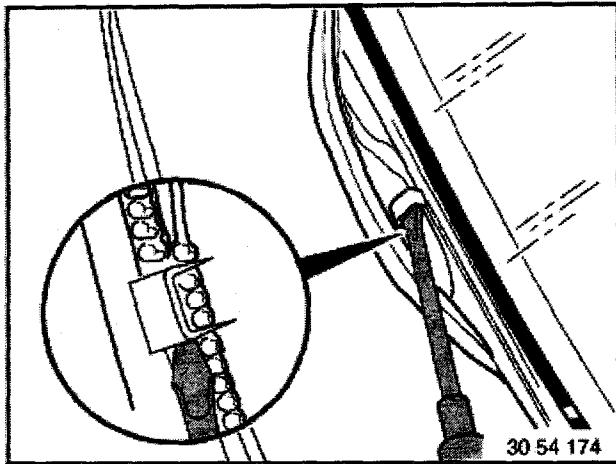

Open zip fastener from inside with folding leg.

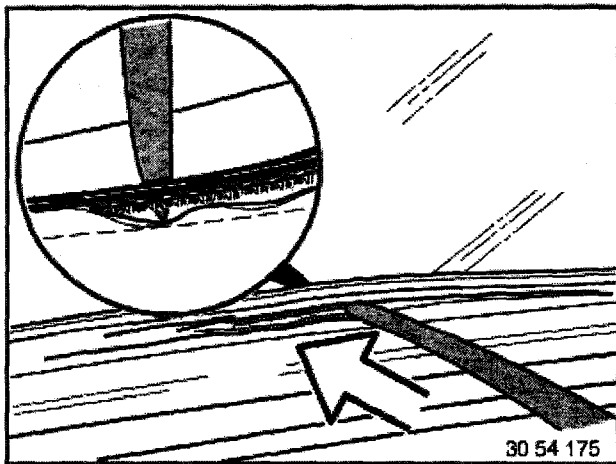

Unfasten rear window from outside by applying gentle pressure and press inwards to remove.

Note:

Completely remove residues of sealing tape from convertible top fabric by hand without using solvents.

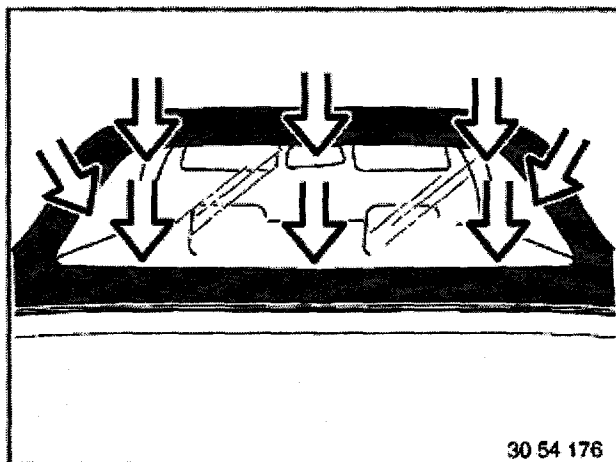

Rear inside window:

Slide zip fastener slide onto underside of rear window on blue zip fastener tape.

Caution!

When installing new rear window,

protect from dirt and damage.

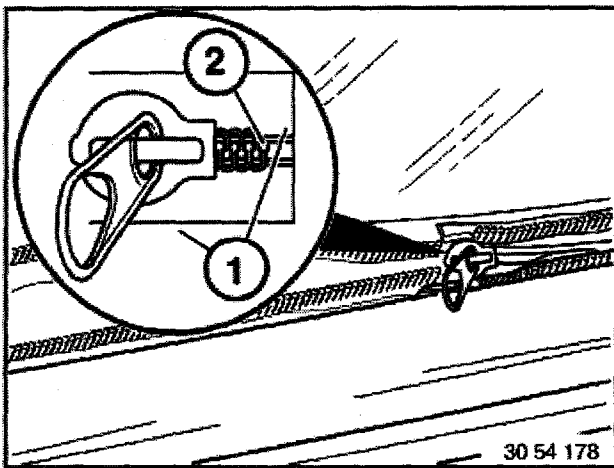
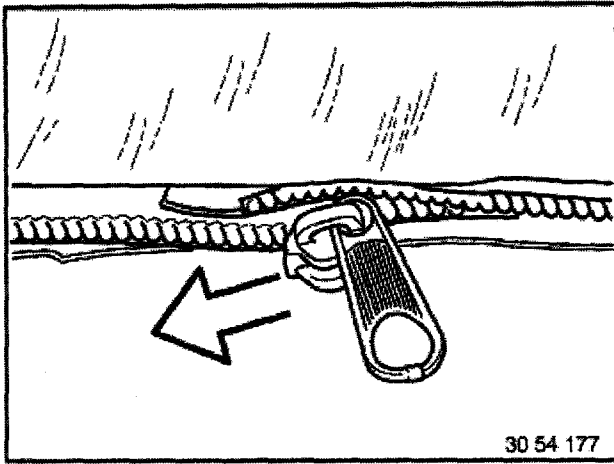

Note:

Assistant holds outside of rear window and ensures that zip fastener slide does not jam.

Insert second half of zip fastener on fabric cover into zip fastener slide so that both leading edges of fabrics (1) are flush with the zip fastener.

First link (2) connects on right or left.

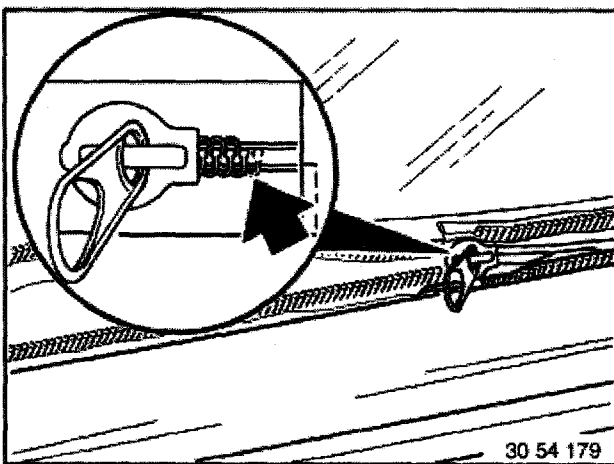

Maximum permitted offset: 1 link to right or left.

Note:

If rear window is slightly wavy, then replace coupling member in other direction.

Slowly close zip fastener and remove zip fastener slide.

Caution!

Zip fastener must not start opening at one end.

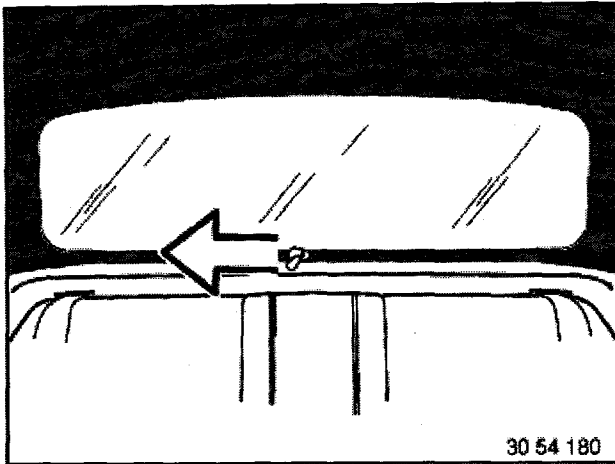

30 54 180

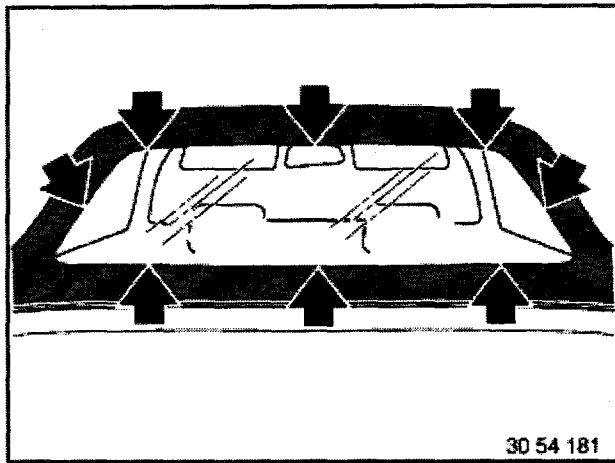

30 54 181

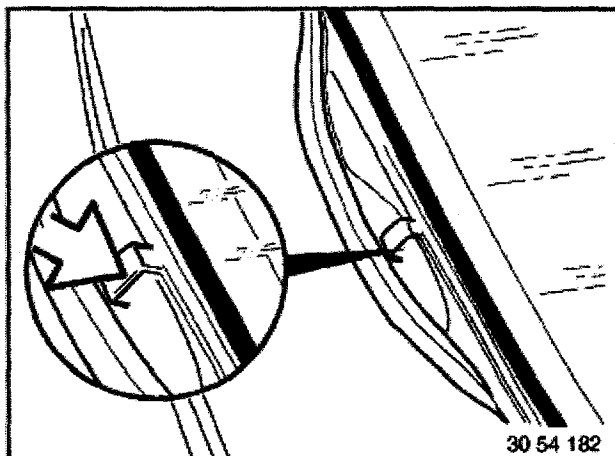

30 54 182

Close convertible top but do not lock it down.

Note:

Check zip fastener (spiral) to ensure that it is closed all around.

Insert retaining clip through zip fastener from outside.

Carefully position opening point for rear window.

Fit counter-support plate to inside and bend claw fasteners into place.

Remove protective film from sealing tape.

Note:

Counterpressure from outside required

on the retaining clip.

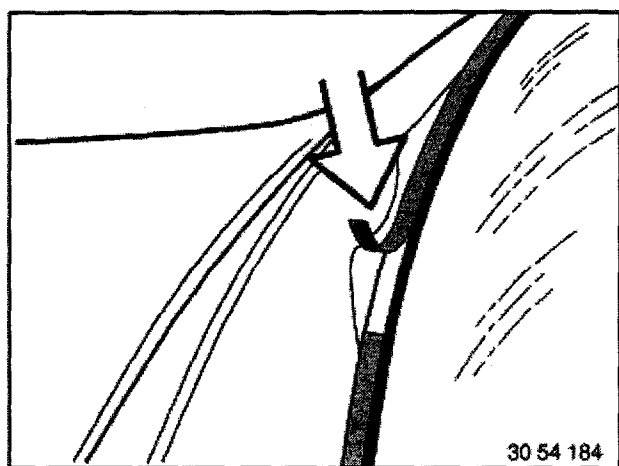
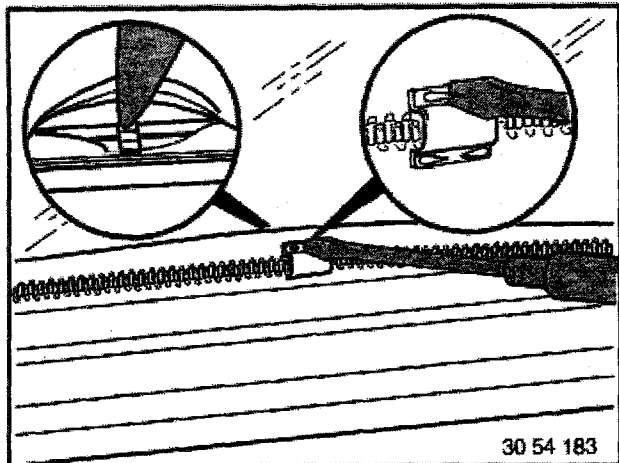

Attach 100 mm of sealing tape on retaining clips flush with profile piping and remove protective film.

Caution!

Place protective card on rear window with fleece face downwards to ensure that this is not damaged when working with the folding leg.

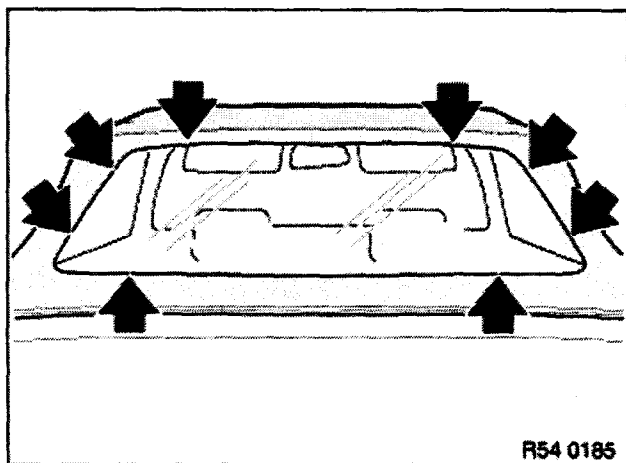

Raise profile piping with folding leg, insert leading edge of fabric and rub vigorously with folding leg.

Note:

Counter support required from inside.

Raise profile piping (3) with folding leg (4) and insert leading edge of fabric (6).

Caution!

Risk of damage to rear window.

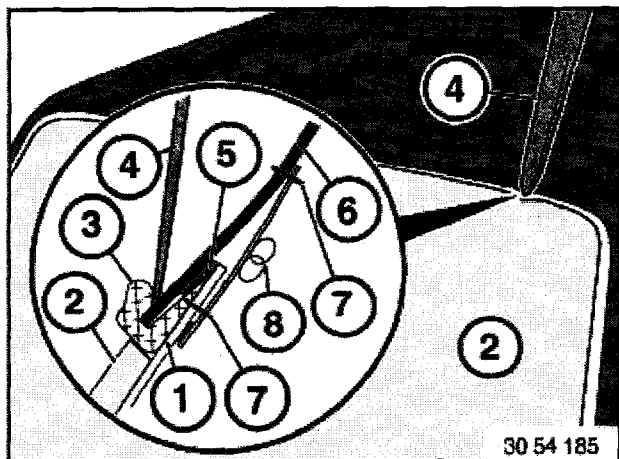

1. Rear window
2. Protective card
3. PVC profile piping
4. Folding leg
5. Sealing tape
6. Cover fabric
7. Seam
8. Zip fastener



Note:

Folds are not permitted.

Rub leading edge of fabric with folding leg:
counter-pressure required from inside.

Remove protective card.

Lock down convertible top.

Caution!

Sealing tape must harden. For this reason, the fabric top must not be folded for the next 24 hours.